

# Science 5-6

## Question Catalogue Index

### I. FOUNDATIONS OF SCIENCE

#### 1. Experimentation

<b>A. Observation, Predictions and Inferences</b>	
i. Observation and Inference.....	1
ii. Distinguishing Observations, Conclusions, Predictions.....	1
iii. Differentiating Observation from Interpretation.....	4
<b>B. Classification &amp; Sequencing</b>	
i. Using a Classification Key.....	5
ii. Classification Systems.....	10
<b>C. Comprehension &amp; Analysis</b>	
i. Interpreting of Graphs & Data.....	12
ii. Drawing Conclusions.....	27

#### 2. Laboratory Skills

<b>A. Measurement and Apparatus</b>	
i. Length, Mass, & Volume.....	31
ii. Temperature.....	41
iii. Density.....	44
iv. Appropriate Instrument Selection.....	48
<b>B. Microscope</b>	
i. Parts and Procedures.....	52
ii. Wet Mount/Staining.....	54
<b>C. Experiment Fundamentals.....</b>	<b>55</b>
<b>D. Testing with Indicators</b>	
i. Acids and Bases, Ph.....	59
<b>E. Laboratory Safety</b>	
i. Using Proper Safety Methods.....	59

### II. ASTRONOMY

#### 1. Our Solar System

<b>A. Motions of Objects in the Sky</b>	
i. Star and Planet Paths.....	61
ii. Geocentric and Heliocentric Models.....	63
iii. The Rotating Earth & Time.....	66
iv. The Elliptical Orbit & Revolution.....	68
v. Earth's Tilted Axis & Seasons.....	69
vi. Moon Phases and Eclipses.....	71
<b>B. Planets, Asteroids, &amp; Meteors</b>	
i. Position & Composition.....	76

#### 2. Gravity

<b>A. Gravitational Forces</b>	
i. Understanding Gravitational Pull.....	80

### III. WEATHER

#### 1. Energy and Our Atmosphere

<b>A. Atmosphere</b>	
i. Properties of Air.....	83
ii. Atmospheric Layers.....	83
<b>B. Heat Transfer</b>	
i. Solar Radiation, Absorption.....	84
ii. Convection.....	85
<b>C. The Water Cycle</b>	
i. Recognizing the Drive of the Water Cycle.....	86
ii. Cycle Processes.....	87
iii. Relative Humidity.....	91
iv. Determining Cloud Type.....	92
<b>D. Weather Patterns</b>	
i. Investigating Weather Factors.....	93
ii. Predicting the Weather.....	94

### IV. EXPLORING THE EARTH

#### 1. Describing Our Earth

<b>A. Earth Structure</b>	
i. Describing the Earth: Atmosphere, Hydrosphere, Lithosphere.....	95
ii. The Crust and Interior of the Earth.....	97
iii. Examining Crustal Movement.....	98
<b>B. Rocks and Soil</b>	
i. Classification of Rocks (Rock Cycle).....	100
ii. Properties of Minerals.....	103
iii. Soil Formation and Composition.....	105
iv. Understanding Earth History & Fossil Evidence.....	107
<b>C. Positions on Earth</b>	
i. Topographical Maps.....	110
<b>D. Land Surface Changes</b>	
i. Weathering Processes.....	113
ii. Evidence and Agents of Erosion.....	116
iii. Factors of Deposition and the Rock Record.....	119
<b>E. Earth's Available Water</b>	
i. Infiltration and the Soil.....	122
ii. The Water Budget.....	122

### V. FORCE, ENERGY, & MOTION

#### 1. Forces & Motion

<b>A. Measuring Motion</b>	
i. Speed, Velocity, Acceleration.....	123
ii. Graphical Representations.....	124
<b>B. Motion Paths</b>	
i. Observing Straight, Circular, & Oscillating Motion .....	126
ii. Inducing Vibration.....	126
<b>C. Forces</b>	
i. Definition and Resultants.....	127
ii. Friction.....	128

<b>2. Energy and Energy Transfer</b>	
<b>A. Forms and Exchanges of Energy</b>	
i. Distinguishing between Electrical, Mechanical, & Chemical.....	129
ii. Differentiating between Kinetic & Potential Energy.....	130
iii. Exchanges between Forms of Energy.....	134
<b>B. Heat</b>	
i. Understanding Heat Flow.....	135
ii. Transfer of Heat Energy: Conduction, Convection, & Radiation .....	137
iii. Phase and Energy Changes .....	139
<b>C. Waves</b>	
i. Transfer of Energy .....	141
ii. Investigating Amplitude, Frequency & Wavelength.....	142
iii. Transmitting Sound through Different Media.....	145
iv. Communication Tools.....	146
<b>D. Light</b>	
i. Understanding the Visible Spectrum.....	146
ii. Distinguishing between Reflection, Refraction, & Diffraction.....	148
iii. Using Optical Tools.....	153
<b>3. Magnetism &amp; Electricity</b>	
<b>A. Magnetism</b>	
i. Distinguishing between Metal & Nonmetal Objects.....	154
ii. Determining the Attraction & Repellence of Magnetic Poles.....	155
<b>B. Electricity</b>	
i. Understanding Static Electricity and Charge Distribution.....	156
ii. Identifying Parts of a Circuit.....	158

## **VI. CHEMISTRY**

<b>1. Properties of Matter</b>	
<b>A. Physical Properties of Matter</b>	
i. Identifying Physical Properties.....	163
ii. Recognizing Phases of Matter and Physical Changes.....	165
<b>B. Chemical Properties of Matter</b>	
i. Defining Chemical Properties and Recognizing Change.....	167
<b>2. Atoms, Elements, Compounds, Mixtures</b>	
<b>A. Subatomic Particles &amp; Their Properties</b>	
i. Distinguishing between Electrons, Protons, & Neutrons.....	167
<b>B. Elements and Compounds</b>	
i. Distinguishing between Elements and Compounds.....	169
<b>C. Mixtures &amp; Solutions</b>	
i. Predicting Liquid Interaction.....	170
ii. Factors Affecting Dissolving.....	171

## VII. LIFE PROCESSES

### 1. Unity and Diversity of Living Things

#### A. Basic Life Units

i. Cell Theory.....	173
ii. Cell Organelles.....	173
iii. Cell Organization.....	177

#### B. Diversity of Life

i. Classification of Organisms .....	177
ii. Distinguishing between Vascular & Nonvascular Plants.....	180
iii. Distinguishing between Vertebrates & Invertebrate.....	181

### 2. Maintenance in Living Things

#### A. Life Functions

i. Nutrition: Autotrophs vs. Heterotrophs.....	182
ii. Homeostasis: Maintaining a Constant Internal Environment.....	184
iii. Respiration: Obtaining Energy for Life Functions.....	185

### 3. Life Functions of Plants

#### A. Characteristics

i. Basic Structure of Plants.....	186
ii. Process of Transport.....	188

#### B. Photosynthesis

i. The Process of Photosynthesis.....	190
ii. The Role of Light.....	192
iii. Cellular Structures.....	193

#### C. Reproduction in Flowers

i. Pollination, Fertilization and Embryo Development.....	194
ii. Germination and Growth.....	198

#### D. Adaptations

i. Effects of Weather and Seasons.....	202
ii. Understanding Dormancy.....	204

### 4. Life Functions of Animals

#### A. Life Cycles

i. Following Offspring to Adult Development.....	204
ii. Distinguishing between Inherited & Acquired Traits.....	208

#### B. Behavioral & Physical Adaptations

i. Understanding Animal Acquisition of Necessities.....	210
ii. Understanding Environmental Adaptations.....	213

#### C. Human Physiology

i. Muscular-Skeletal System.....	218
ii. Digestive and Excretory Systems.....	220
iii. Nervous System.....	223
iv. Respiratory and Circulatory Systems.....	224

## VIII. ECOLOGY

### 1. Ecosystems

#### A. Living & Nonliving Interaction

i. Understanding Interdependence.....	225
---------------------------------------	-----

#### B. Ecosystems

i. Abiotic, Biotic and Limiting Factors.....	226
ii. Describing an Ecosystem.....	228

iii. Understanding Populations and Communities.....	231
iv. Niche Competition.....	233
v. Investigating Terrestrial and Aquatic Biomes.....	235
<b>C. Energy Relationships</b>	
i. Distinguishing between Producers and Consumers.....	237
ii. Distinguishing between Herbivore, Carnivore, & Omnivore.....	240
iii. Reading Food Chains & Webs.....	243
iv. Pyramids and Energy Flow.....	249
<b>D. Material Cycles</b>	
i. The Carbon-Hydrogen-Oxygen Cycle.....	254
ii. The Water Cycle: The Role of Organisms.....	255
iii. The Nitrogen Cycle and the Role of Decomposers.....	256
<b>E. Nutritional Relationships</b>	
i. Predatory-Prey Relationship.....	258
ii. Symbiosis: Parasitism and Mutualism.....	260

## **IX. RESOURCES**

### **1. Human Influences on the Environment**

<b>A. Management of Resources</b>	
i. Identifying Natural Resources: Renewable and Non-Renewable.....	261
ii. Describing Everyday, Recyclable Materials.....	261
iii. Distinguishing between Natural Energy & Fossil Fuel.....	262
iv. Understanding Electricity & Nuclear Power.....	262
<b>B. Ecological Concerns</b>	
i. Recognizing Factors that Affect Air & Water Quality.....	263
ii. Determining Land Usage.....	265
iii. Conservation and Preservation.....	266
<b>C. Technology</b>	
i. Determining Uses & Consequences of Technology.....	268
ii. History of Technology.....	269

### **2. Environmental Effects on Organisms**

<b>A. Environmental Effects on Organisms</b>	
i. Impacts of Fire, Disease, Water, & Land Movements.....	269

# UNIT I

---



## FOUNDATIONS OF SCIENCE

209. Luann inflates a balloon to a volume of 2000 cubic centimeters ( $\text{cm}^3$ ). Every hour, she puts the balloon into a room with a different air temperature. At the end of each hour, Luann measures the balloon's volume in that room. Luann records her information in the table below.

VOLUME OF A BALLOON IN DIFFERENT TEMPERATURES

Room	A	B	C	D
Temperature of air in room	20°C	25°C	30°C	35°C
Volume of balloon	2020 $\text{cm}^3$		2060 $\text{cm}^3$	2080 $\text{cm}^3$

What is the volume of the balloon in Room B?

- (1) 2050  $\text{cm}^3$   
 (2) **2040  $\text{cm}^3$**   
 (3) 2030  $\text{cm}^3$   
 (4) 2000  $\text{cm}^3$

42. Jan, Tom, Dick, and Ana each use a sponge to make identical wet streaks on the class chalkboard. Each person stands 1 meter from his or her wet streak and does a different activity. Jan, Tom, and Dick record the time it takes their own wet streak to dry.

CHALKBOARD DRYING TIMES

Person	Activity	Time it takes wet streak to dry
Jan	Nothing	1 min, 50 seconds
Tom	Wave hands at wet streak	1 min, 5 seconds
Dick	Aims hot hair dryer at wet streak	25 seconds
Ana	Aims electric fan at wet streak	

Predict how long it takes Ana's streak to disappear. Explain the reasons for your answer.

**Accept answers between 30 seconds and 1 minute. Explanations may vary.**  
**The hair dryer is like a fan but with hot air.**  
**Hot air dries wet objects faster than room temperature air. A fan is better than waving one's hand.**

136. The hamsters in Palila's classroom had babies three weeks ago. She wrote these observations in her science journal.

HAMSTER OBSERVATIONS

	Weight	Color	Activity
Hamster 1	3 grams	brown	moves little
Hamster 2	2 grams	white	always moves
Hamster 3	2 grams	black	moves some
Hamster 4	4 grams	tan	moves very little

Which would be the best conclusion from Palila's observations?

- (1) Hamsters are usually tan in color.  
 (2) Hamsters do not weigh any more than 3 grams.  
 (3) **Hamsters come in many colors and sizes.**  
 (4) All hamsters are very active.
655. Justin thinks that his baseball team will win the championship. This is an example of a(n)
- (1) conclusion. (3) inference.  
 (2) observation. (4) **prediction.**



Base your answers to questions 651 through 654 on the classification key below.

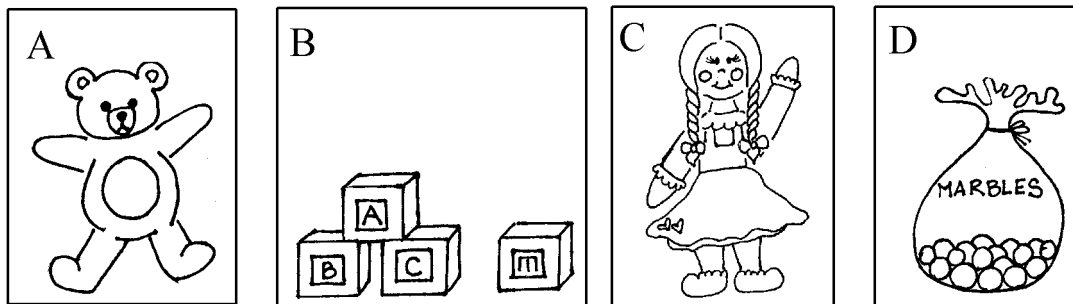

Toy Flowchart

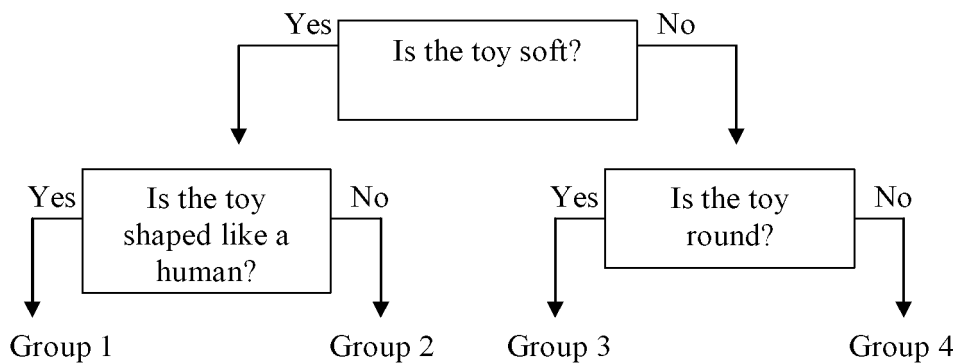

651. Which of the following toys belongs to Group 4?

- (1) *A*                      (2) ***B***                      (3) *C*                      (4) *D*

652. Which of the following toys belongs to Group 2?

- (1) *A*                      (2) *B*                      (3) *C*                      (4) *D*

653. Which of the following groups does Toy B belong to?

- (1) Group 1                      (2) Group 2                      (3) Group 3                      (4) **Group 4**

654. Which of the following groups does Toy C belong to?

- (1) **Group 1**                      (2) Group 2                      (3) Group 3                      (4) Group 4

37. Objects can often be separated into groups based on their characteristics. Look at the keys below.

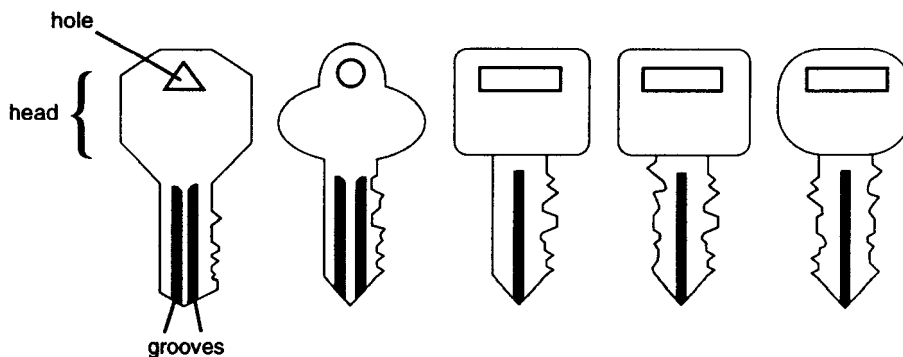

Which one of the following characteristics could NOT be used to separate these keys into groups?

- (1) The shape of the key head.
- (2) The number of grooves in the key.
- (3) The number of holes in the key head.
- (4) The shape of the hole in the key head.

142. Base your answer to the following question on the animals below.

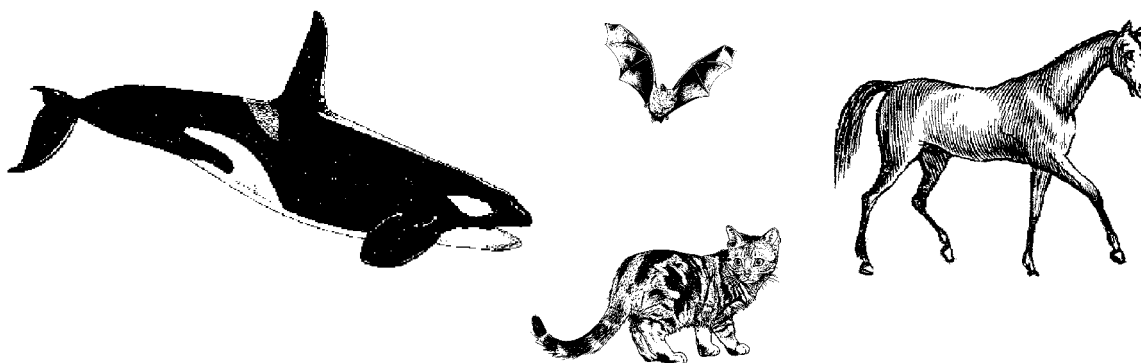

Which two are most alike? Explain your answer. Give at least two reasons for your answer.

**Example:**

**–Horse and Cat. –Both are land animals with four legs.**

410. Base your answer to the following question on the shapes below.



What would be an appropriate way to set the objects above into two groups?

- (1) Color
- (2) **Number of sides**
- (3) Size
- (4) Temperature

734. The primary purpose of a classification system is to enable people to

- (1) make measurements that are very accurate.
- (2) eliminate inaccurate inferences.
- (3) **organize observations in a meaningful way.**
- (4) extend their powers of observation.



# UNIT II

---



ASTRONOMY

681. The diagram below represents the moon's path around the Earth.

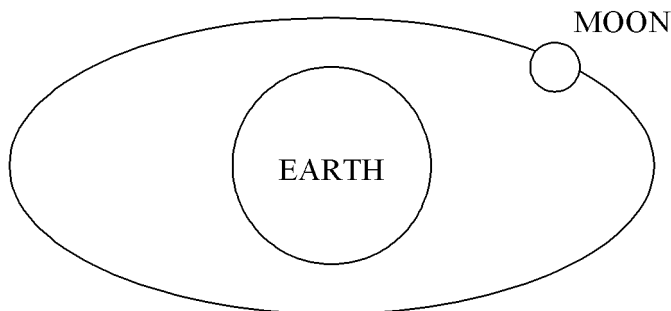

(Not drawn to scale)

The motion of the moon represented in the diagram is called

- (1) a rotation
- (2) a revolution
- (3) spinning
- (4) a vibration

1099. Which diagram best represents the motions of celestial objects in a heliocentric model?

Key:  
 P● = Planet  
 M● = Moon  
 S⊙ = Sun

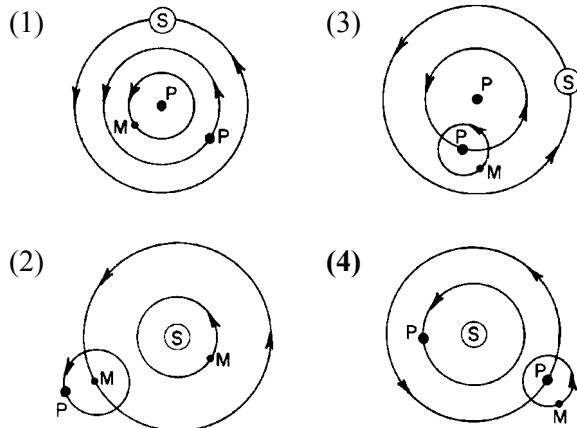

682. Which diagram below shows the sun-centered model of the solar system?

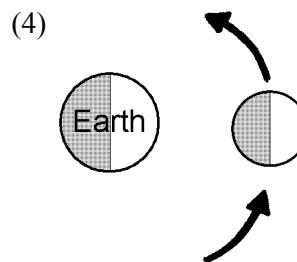
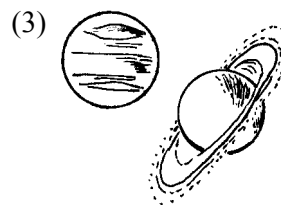
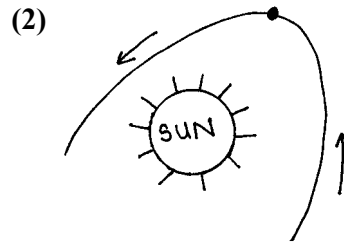
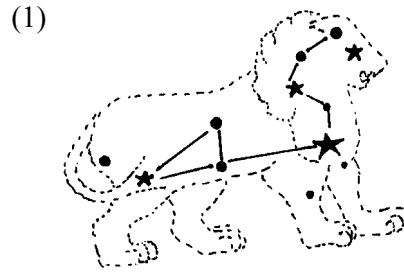

1224. Which statement best describes a geocentric model of our solar system?

- (1) The Earth is located at the center of the model.
- (2) All planets revolve around the Sun.
- (3) The Sun is located at the center of the model.
- (4) All planets *except* the Earth revolve around the Sun.

133. What would probably happen if it took the Earth longer to orbit the Sun than it does now?
- (1) a year would have fewer than 365 days
  - (2) a year would have more than 365 days**
  - (3) winters would be warmer
  - (4) the moon would be brighter

160. It takes 365 days for the Earth to revolve around the sun. What effect would it have if the Earth were to revolve faster?
- (1) days would be shorter
  - (2) years would be longer
  - (3) days would be longer
  - (4) years would be shorter**

295. How long does it take for the Earth to revolve around the Sun?
- (1) a week
  - (2) a month
  - (3) a single day
  - (4) a year**

327. The Earth revolves around the Sun. How long does it take the Earth to make one complete revolution?
- (1) 7 days
  - (2) 365  $\frac{1}{4}$  days**
  - (3) 356  $\frac{1}{4}$  days
  - (4) 30 days

437. Which of the following takes approximately one year?
- (1) the Earth's revolution around the sun**
  - (2) the Earth's rotation
  - (3) the moon's revolution around the Earth
  - (4) the moon's revolution around the sun

746. James wants to measure the temperature inside and outside of his refrigerator using a thermometer. He should
- (1) measure the temperature inside the refrigerator and then immediately measure the outside temperature
  - (2) measure the temperature outside the refrigerator and then immediately measure the inside temperature
  - (3) measure the temperature outside the refrigerator and then leave the thermometer in the refrigerator for two hours before measuring the inside temperature**
  - (4) using two different thermometers, immediately measure the temperatures inside and outside of the refrigerator at the same time

1121. Some constellations (star patterns) observed in the summer skies are different from those observed in the winter skies. The best explanation for this observation is that

- (1) the Earth revolves around the Sun**
- (2) the Earth rotates on its axis
- (3) constellations are moving away from the Earth
- (4) constellations revolve around the Earth

1167. The diagram below shows the Earth's position in its orbit around the Sun at the beginning of each season. The Moon is shown at various positions as it revolves around the Earth.

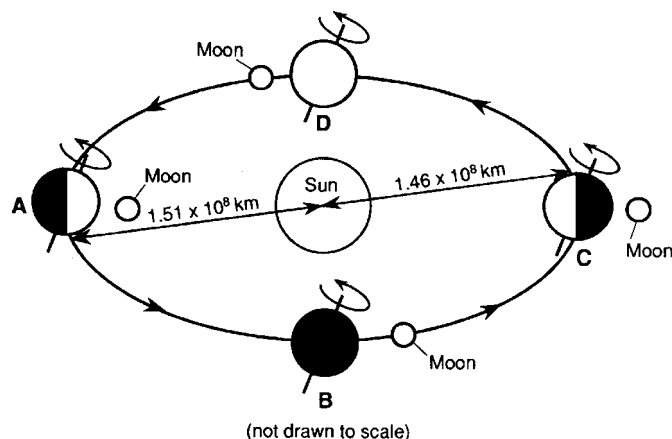

The Earth's orbit around the Sun is best described as

- (1) a perfect circle
- (2) an oblate spheroid
- (3) a very eccentric ellipse
- (4) a slightly eccentric ellipse**

1460. How long does Earth take to complete one orbit around the Sun?

- (1) 1 day
- (2) 1 month
- (3) 1 year**
- (4) 1 decade

1487. It is necessary to add a day to the calendar every four years because

- (1) the axis of Earth is tilted.
- (2) the gravitational pull of the Sun affects Earth's revolution.
- (3) the revolution of Earth is not exactly 365 days.**
- (4) the Moon crosses the orbit of the Sun every 28 days.

# UNIT III

---



WEATHER

Base your answers to questions 165 through 169 on the Water Cycle diagram below.

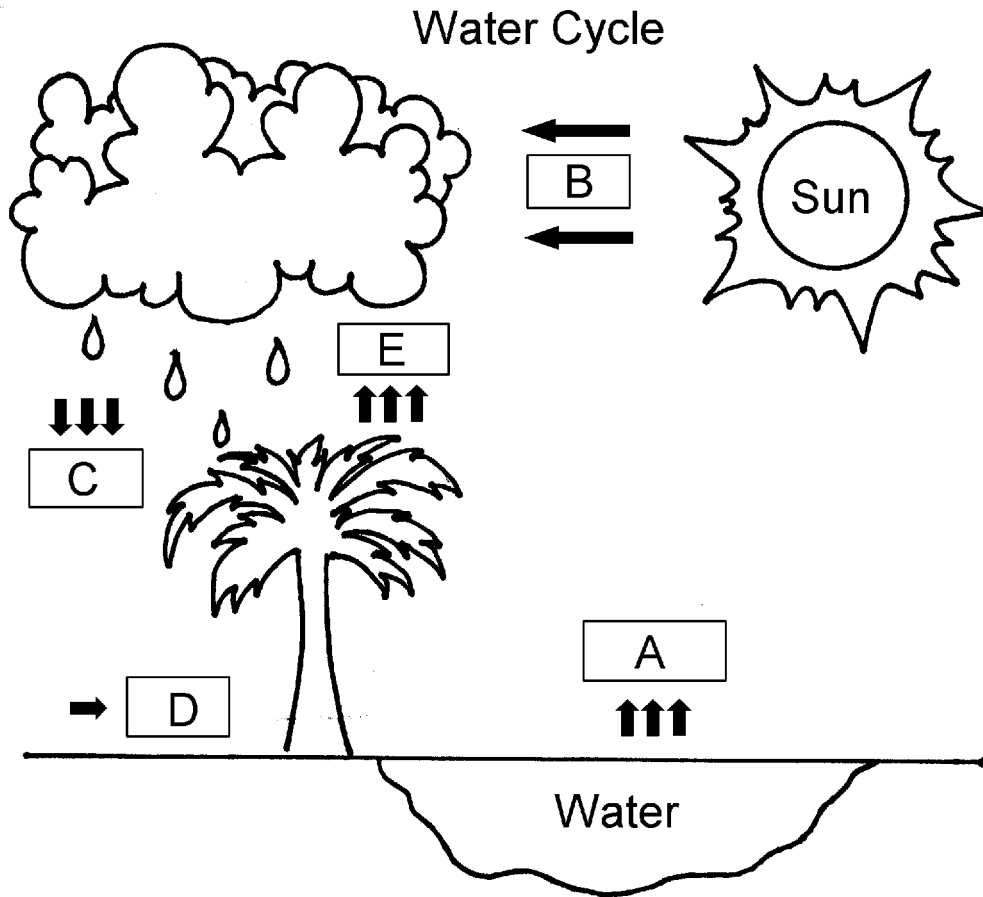

165. What is happening in Box A?  
 (1) **water is evaporating** (2) water is condensing (3) water is freezing (4) water is precipitating
166. As water vapor rises into the sky it is cooled and forms into a cloud. What is this called?  
 (1) transpiration (2) evaporation (3) **condensation** (4) collection
167. In the diagram, Box D represents  
 (1) loss of water (2) **run-off** (3) evaporation of water (4) perspiration of water
169. Box E represents the transpiration of water. What is the definition of transpiration?  
 (1) The holding onto of water by plants and trees.  
 (2) **The release of water vapor from openings in the leaves of plants.**  
 (3) The absorption of water through plants and trees.  
 (4) The usage of water by plants and trees.

733. Which substance is a form of precipitation?

- (1) frost (3) fog  
 (2) **hail** (4) dew

1139. A container of water is placed in an open area outdoors so that the evaporation rate may be observed. The water will probably evaporate fastest when the air is

- (1) cool and humid (3) warm and humid  
 (2) cool and dry (4) **warm and dry**

335. The diagram below shows the water cycle.

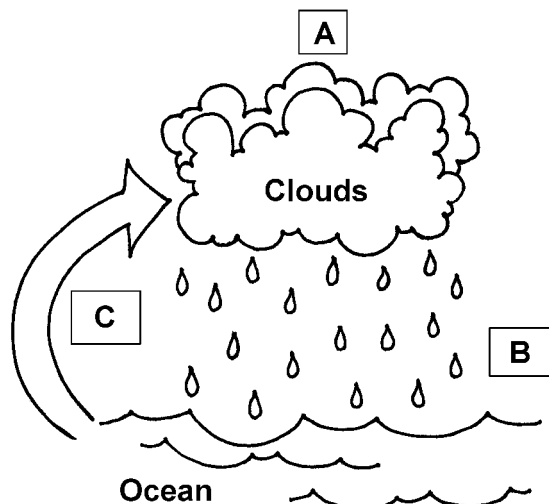

Part A shows which part of the water cycle?

- (1) evaporation                      (3) rain  
(2) **condensation**                  (4) precipitation

728. A diagram of the water cycle is shown below. Letters A through D represent the processes taking place.

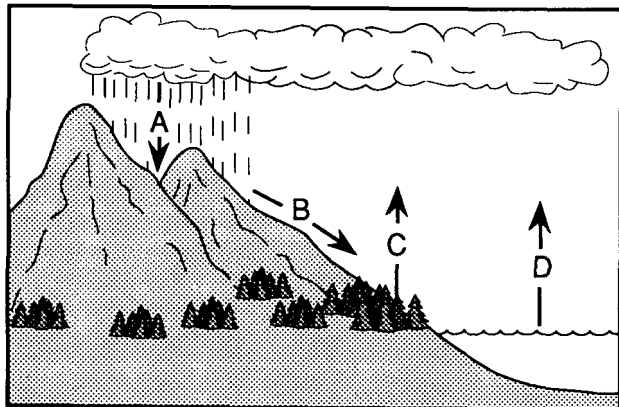

Which arrow represents the process of transpiration?

- (1) A                                      (3) C  
(2) B                                      (4) D

1160. Water vapor enters the atmosphere by the processes of evaporation and

- (1) condensation                      (3) **transpiration**  
(2) precipitation                      (4) conduction

1128. Which statement best explains how atmospheric dust particles influence the water cycle?

- (1) Dust particles are the main source of dissolved salts in the sea.  
(2) Dust particles increase the capacity of the atmosphere to hold water vapor.  
(3) Dust particles increase the amount of evaporation that takes place.  
(4) **Dust particles provide surfaces on which water vapor can condense.**

1170. Which is caused by evaporation and transpiration?

- (1) The atmosphere warms.  
(2) Cloud cover decreases.  
(3) **Moisture enters the atmosphere.**  
(4) Moisture leaves the atmosphere.

1203. By which process are clouds, dew, and fog formed?

- (1) **condensation**                      (3) precipitation  
(2) evaporation                      (4) melting

1217. Which statement best explains why a cloud is forming as shown in the diagram below?

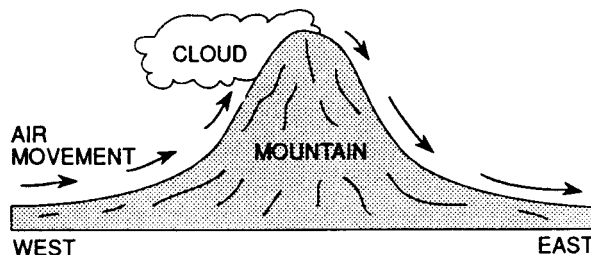

- (1) **Water vapor is condensing.**  
(2) Moisture is evaporating.  
(3) Cold air rises and compresses.  
(4) Warm air sinks and expands.

1237. The flowchart below shows one process by which moisture enters the atmosphere.

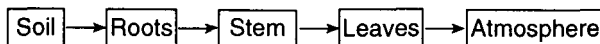

The last step of this process is known as

- (1) condensation                      (3) radiation  
(2) convection                      (4) **transpiration**

# UNIT V

---

## FORCE, ENERGY, AND MOTION

A. Measuring Motion

i. Speed, Velocity, Acceleration

190. the picture below.

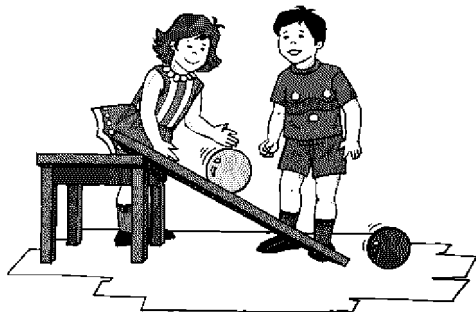

Jen and Lee are rolling balls down a ramp. What is the ball gaining as it rolls down the ramp?

- (1) mass
- (2) **speed**
- (3) shape
- (4) height

205. What would be the safest thing to do when handling a plant you have never seen before?

- (1) Only handle it for a few minutes.
- (2) **Put gloves on before touching it.**
- (3) Wash your hands before touching it.
- (4) Wash your hands after touching it.

1110. Which of the measuring devices shown below are most likely to be used to measure the speed of the water flowing in a stream?

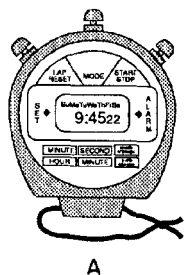

A

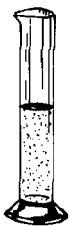

C

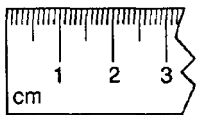

B



D

- (1) **A and B, only**
- (2) C and D, only
- (3) A, B, and D, only
- (4) A, B, C, and D

1335. An object moves a distance of 10 meters in 5 seconds. The average speed of the object is

- (1)  $\frac{1}{2}$  m/sec
- (2) **2 m/sec**
- (3) 40 m/sec
- (4) 50 m/sec

1317. An object originally at rest is uniformly accelerated along a straight-line path to a speed of 8.0 meters per second in 2.0 seconds. What was the acceleration of the object?

- (1) 0.25 m/s<sup>2</sup>
- (2) 10. m/s<sup>2</sup>
- (3) 16 m/s<sup>2</sup>
- (4) **4.0 m/s<sup>2</sup>**

1319. An object is uniformly accelerated from rest to a speed of 25 meters per second in 10 seconds. The acceleration of the object is

- (1) 1.0 m/s<sup>2</sup>
- (2) 2.0 m/s<sup>2</sup>
- (3) 1.5 m/s<sup>2</sup>
- (4) **2.5 m/s<sup>2</sup>**

1334. The average speed of an object is 2 meters per second. What is the total distance traveled by the object during 6.0 seconds?

- (1)  $\frac{1}{3}$  m
- (2) **12 m**
- (3) 3 m
- (4) 4 m

1358. What is the distance traveled by an object that moves with an average speed of 6.0 meters per second for 8.0 seconds?

- (1) 0.75 m
- (2) 1.3 m
- (3) 14 m
- (4) **48 m**

1360. A cart travels a distance of 30 meters in 15 seconds. The average speed of the cart is

- (1) 0.20 m/s
- (2) **2.0 m/s**
- (3) 0.50 m/s
- (4) 5.0 m/s

1361. A runner completed the 100 meter dash in 10 seconds. The average speed was

- (1) 1 m/s
- (2) **10 m/s**
- (3) 100 m/s
- (4)  $\frac{1}{10}$  1,000 m/s

1417. The average velocity of an object can be determined by the formula

- (1) distance  $\times$  time
- (2)  $\frac{\text{change in distance}}{\text{change in time}}$
- (3)  $\frac{\text{acceleration}}{\text{change in time}}$
- (4)  $\frac{\text{change in time}}{\text{change in distance}}$

A. Measuring Motion

ii. Graphical Representations

Base your answers to questions 1321 and 1322 on Cars A and B both start from rest at the same location at the same time.

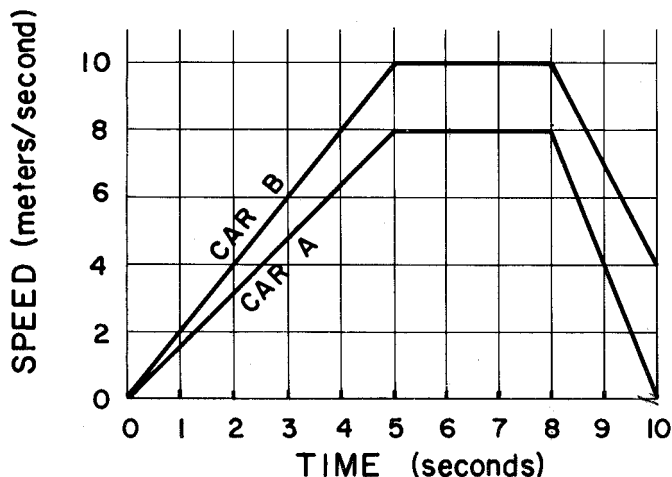

1321. Compared to the speed of car B at 6 seconds, the speed of car A at 6 seconds is

- (1) less
- (2) greater
- (3) the same

1322. Compared to the total distance traveled by car B during the 10 seconds, the total distance traveled by car A is

- (1) less
- (2) greater
- (3) the same

1350. Which graph represents an object that is moving at a constant speed for the entire time interval?

- (1)
- (2)
- (3)
- (4)

1371. The graph at the right represents the motion of a body that is moving with

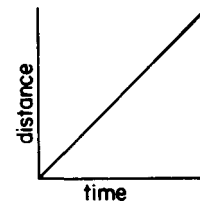

- (1) increasing acceleration
- (2) decreasing acceleration
- (3) increasing speed
- (4) constant speed

1380. The uniform motion of a cart is shown in the distance versus time graph below. What is the average speed of the cart?

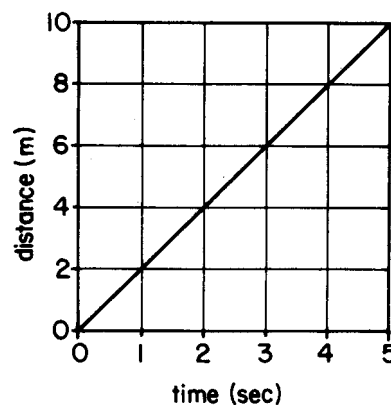

- (1) 0.5 m/s
- (2) 2 m/s
- (3) 5 m/s
- (4) 50 m/s

1382. The graph below shows the distance traveled by an object plotted against time.

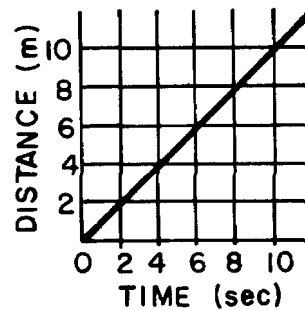

What is the distance covered by the object between the 2nd and 6th second?

- (1) 8 m
- (2) 2 m
- (3) 6 m
- (4) 4 m

6. Use the picture below to answer the following question.

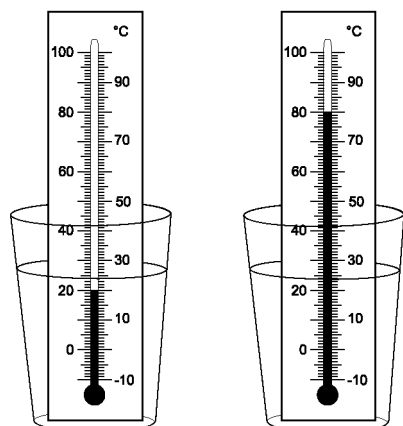

Picture A

Picture B  
(same glass,  
10 minutes later)

Which of the following might have happened to the glass in Picture A to cause the temperature to change as shown in Picture B?

- (1) The glass was placed in the refrigerator for 10 minutes.
- (2) Cold water was added to the glass.
- (3) The glass was taken from a sunny place and put in a shady place.
- (4) The glass was placed in hot water.**

78. When cold water is heated, the speed of the water molecules

- (1) increases**                      (3) remains the same
- (2) decreases                      (4) stop

140. If you put a hot brick in a bucket of cold water and left it for a while, what would happen?

- (1) The brick would get warmer and the water would get cooler.
- (2) The brick would get cooler and the water would get warmer.**
- (3) The brick would get as cold as the water had been.
- (4) The water would get as hot as the brick had been.

122. Tasha has the two objects drawn below. One is a metal ring on a stick and one is a metal ball on a stick. The ball can just squeeze through the ring.

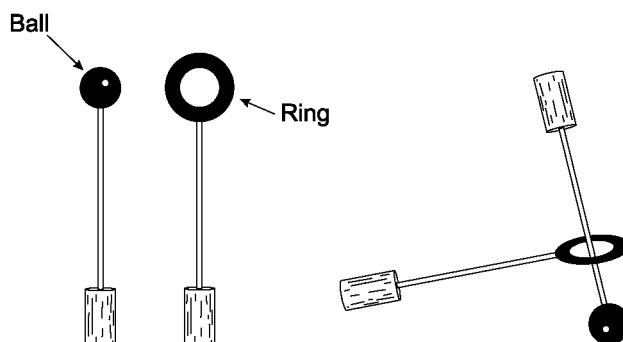

If Tasha heats the metal ball, she will probably notice that

- (1) the ball will contract and pass through the ring more easily
- (2) the ball will gain mass and become heavier
- (3) the ball will expand and not fit through the ring**
- (4) the ball will be magnetized and be attracted to the ring

224. Which of the following materials is the best insulator?

- (1) copper                              **(3) wood**
- (2) nickel                              (4) gold

228. What part of a house should have the most insulation to keep the most heat in?

- (1) ceiling**                              (3) door
- (2) floor                                (4) wall

416. If warm water is poured into a cold glass, the water will most likely

- (1) get cooler and the glass will get cooler
- (2) get hotter and the glass will get warmer
- (3) get cooler and the glass will get warmer**
- (4) stay warm and the glass will stay cool

1144. Heat flows between two objects that are close to each other if the objects have different

- (1) specific heats                      (3) masses
- (2) temperatures**                      (4) densities

# UNIT VI

---



CHEMISTRY

## VI. CHEMISTRY

### A. Physical Properties of Matter

36. A glass of ice water is taken from a refrigerator. A picture is made of the glass when it is first placed on a table. Another picture is made 10 minutes later.

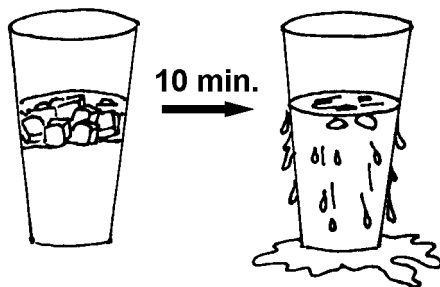

Name a physical change that has taken place. Describe the energy flow or force that caused this change.

**Example: Condensation, as heat from the water vapor in air was absorbed by glass, condensing vapor into liquid water.**

46. Popcorn is a moist corn surrounded by a hard shell. Popcorn kernels generally pop when they are heated to about 200°F. Identify two physical changes that occur when popcorn kernels pop.

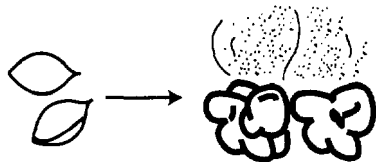

**They get bigger and they turn white in color.**

59. Water vapor that condenses on cool surfaces is

- (1) dew (3) snow  
(2) rain (4) sleet

75. Which of the following lists contains the three phases of matter?

- (1) water, rock and air  
(2) color, texture and hardness  
(3) **liquid, solid, and gas**  
(4) wet, dry, and hard

357. Matter changes from a gas to a liquid by

- (1) melting (3) evaporating  
(2) **condensing** (4) expanding

## 1. Properties of Matter

### ii. Recognizing Phases of Matter and Physical Changes

76. How could you change apple juice to a different state of matter?

- (1) put ice cubes in it  
(2) **put it into the freezer**  
(3) pour it down a drain  
(4) mix it with orange juice

129. Victor has two glasses. One glass is filled with ice cubes and the other is filled with water.

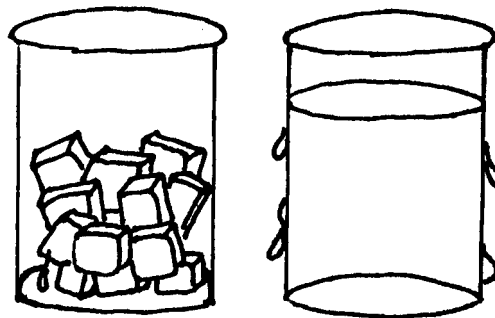

Give three ways the ice and water are different.

**Examples - The ice cubes are colder than the water. - The water is a liquid and the ice cubes are solid. - The water fills more of the glass than the ice cubes.**

170. Each container holds the same amount of water. If they are left out in the sun for the same amount of time, which container would lose the *least* amount of water to evaporation?

(1)

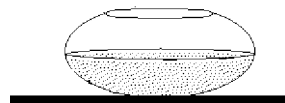

(2)



(3)

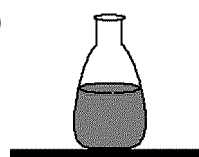

(4)

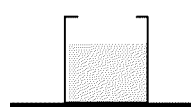

## A. Subatomic Particles &amp; Their Properties

## i. Distinguishing between Electrons, Protons, &amp; Neutrons

422. Which of the following has a negative charge?

- (1) a proton (3) a neutron  
**(2) an electron** (4) a positron

568. An electron has a charge that is

- (1) positive (3) zero  
**(2) negative** (4) none of the above

Base your answers to questions 756 through 758 on the diagram below of an atom.

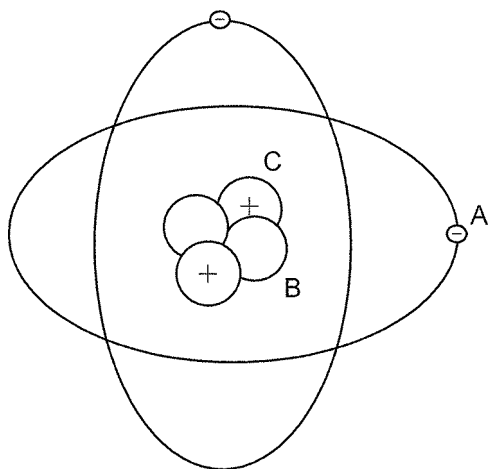

756. What is the name of the particle labeled A?

- (1) proton **(3) electron**  
 (2) neutron (4) neutrino

757. What is the name of the particle labeled B?

- (1) proton (3) electron  
**(2) neutron** (4) neutrino

758. What is the name of the particle labeled C?

- (1) proton** (3) electron  
 (2) neutron (4) neutrino

1264. Which particle is electrically neutral?

- (1) proton **(3) neutron**  
 (2) ion (4) electron

1269. Which particle has approximately the same mass as a proton?

- (1) alpha (3) electron  
**(2) beta** **(4) neutron**

1274. Which particles account for most of the mass of the atom?

- (1) protons and neutrons**  
 (2) protons and electrons  
 (3) neutrons and electrons  
 (4) neutrons and positrons

1277. Which of the following particles has the *least* mass?

- (1) proton (3) neutron  
 (2) hydrogen nucleus **(4) electron**

1278. Which of the following particles has the smallest mass?

- (1) neutron (3) proton  
**(2) electron** (4) hydrogen atom

1279. Which of the following particles has the *least* mass?

- (1) an electron** (3) an ion  
 (2) a proton (4) a neutron

1280. Which is an alkaline earth metal?

- (1) Na (3) Ga  
**(2) Ca** (4) Ta

1283. The major portion of an atom's mass consists of

- (1) electrons and protons  
 (2) electrons and neutrons  
 (3) neutrons and positrons  
**(4) neutrons and protons**

1286. Compared to the whole atom, the nucleus of the atom is

- (1) smaller and contains most of the atom's mass**  
 (2) smaller and contains little of the atom's mass  
 (3) larger and contains most of the atom's mass  
 (4) larger and contains little of the atom's mass

1287. Which particle in the atom has a positive charge?

- (1) a neutron (3) a beta particle  
**(2) a proton** (4) an alpha particle

1290. Compared to the charge and mass of a proton, an electron has

- (1) the same charge and a smaller mass  
 (2) the same charge and the same mass  
**(3) an opposite charge and a smaller mass**  
 (4) an opposite charge and the same mass

**VI. CHEMISTRY****B. Elements and Compounds****2. Atoms, Elements, Compounds, Mixtures****i. Distinguishing between Elements and Compounds**

383. Carbon dioxide gas is classified as a(n)  
(1) element                      **(3) compound**  
(2) solution                      (4) mixture
384. Pure gold is classified as  
**(1) a metallic element**  
(2) a nonmetallic element  
(3) a metallic compound  
(4) a nonmetallic compound
393. What is the smallest unit of an element that shares the element's properties?  
(1) molecule                      **(3) atom**  
(2) cell                              (4) compound
425. Pure copper is an example of  
(1) a compound                      (3) a fluid  
(2) a mixture                      **(4) an element**
1265. Which of the following substances can *not* be broken down by chemical change?  
(1) sulfuric acid                      (3) water  
(2) table salt                      **(4) helium**
1268. Which substance can be broken down by a chemical change?  
(1) sodium                              (3) sulfur  
(2) argon                              **(4) ammonia**
1273. Which substance can not be broken down into simpler substances?  
(1) a salt crystal                      (3) gasoline  
**(2) aluminum**                      (4) water
1282. Which element is an inert (noble) gas?  
(1) bromine                              (3) sulfur  
**(2) argon**                              (4) oxygen
1284. Which substance can be broken down by a chemical change?  
(1) beryllium                              **(3) water**  
(2) boron                              (4) magnesium
1288. Which is the formula of a compound?  
(1) Ca                                      (3) N  
(2) Cl                                      **(4) HF**
1293. Water is  
(1) an element                              (3) a mixture  
**(2) a compound**                              (4) a solution
1296. Elements that will **not** combine with other elements are classified as  
(1) metals                                      **(3) noble gases**  
(2) nonmetals                              (4) metalloids
1299. Which substance is an example of a compound?  
(1) sulfur                                      (3) helium  
**(2) sugar**                                      (4) iron
1303. When two or more different elements unite chemically, they form a  
**(1) compound**                              (3) metalloid  
(2) mixture                              (4) solution
1305. An example of a compound is  
(1) seawater                                      (3) petroleum  
(2) wood                                      **(4) sodium chloride**
1306. Neon and sodium are examples of  
(1) metalloids                                      (3) mixtures  
(2) compounds                                      **(4) elements**
1411. What happens when elements chemically combine?  
(1) All elements retain their original properties.  
**(2) New properties are formed.**  
(3) Only metals retain their original properties.  
(4) New elements are formed.
1506. Which statement concerning elements is true?  
(1) Different elements must have different numbers of isotopes.  
(2) Different elements must have different numbers of neutrons.  
(3) All atoms of an element must have the same mass.  
**(4) All atoms of a given element must have the same number of protons.**

# UNIT VII.

---



LIFE PROCESSES

457. Base your answer to the following question on the table below.

**ORGANISM CLASSIFICATIONS**

Category	Organism A	Organism B	Organism C	Organism D
Kingdom	Plant	Animal	Animal	Animal
Phylum	Tracheophyta	Chordata	Chordata	Chordata
Genus	Taraxacum	Canis	Canis	Homo
Species	<i>officinale</i>	<i>familiaris</i>	<i>lupus</i>	<i>sapiens</i>

Which of the following organisms have cells with cell walls?

- (1) A only                      (2) B only                      (3) A and B                      (4) C and D

388. Which of the following cell structures are in plants but not in animals?

- (1) cell membrane              (3) vacuoles  
(2) cell wall                      (4) nucleus

445. The diagram below shows a cell.

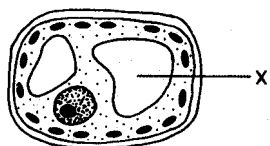

What is the function of the structure labeled X?

- (1) hold genetic material      (3) store waste  
(2) create energy              (4) make proteins

Base your answers to questions 446 and 447 on the diagram below.

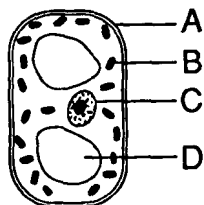

446. Which of the following provides structure and support to the cell?

- (1) A                              (3) C  
(2) B                              (4) D

447. Which of the following structures is the nucleus?

- (1) A                              (3) C  
(2) B                              (4) D

Base your answers to questions 448 and 449 on the diagram of Cell I and Cell II.

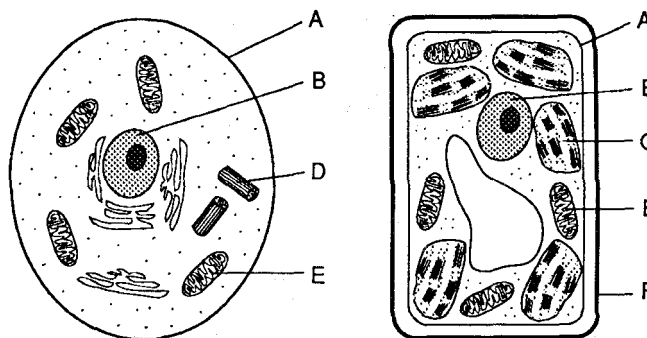

CELL I

CELL II

448. Which of the cells belongs to an animal?

- (1) Cell I  
(2) Cell II  
(3) Both cell I and II  
(4) Neither cell I or cell II

449. Which of the following structures differentiate a plant cell from an animal cell?

- (1) A                              (3) E  
(2) B                              (4) F

450. What is the name of the fluid that the cell organelles float in?

- (1) membrane                  (3) nucleus  
(2) cytoplasm                  (4) vacuole

452. Compared to the cell membrane, the cell wall is

- (1) softer                          (3) stronger  
(2) weaker                        (4) more flexible

451. Base your answer to the following question on the diagram below.

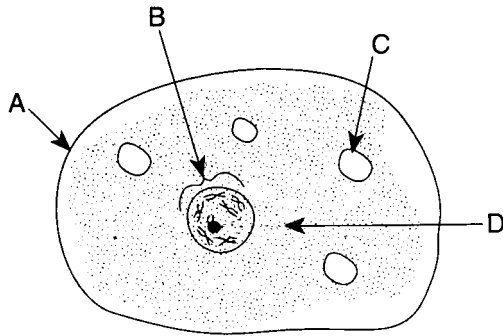

Which structure is the "control center" of the cell?

- (1) A
- (2) B
- (3) C
- (4) D

464. Plant cells tend to be shaped like which of the following?

- (1)
- (2)
- (3)
- (4)

465. Base your answer to the following question on the diagram below.

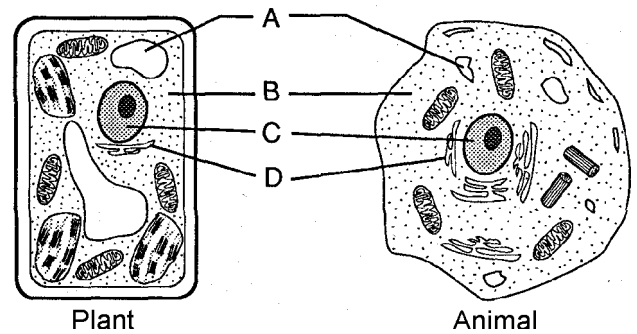

What conclusion can you make from this diagram?

- (1) animal cells are shaped rectangularly
- (2) animal and plant cells have nothing in common
- (3) **animal and plant cells have many of the same cell structures**
- (4) plant cells don't have cytoplasm

471. Jordanna took a toothpick and scraped off cheek cells from inside her mouth. She looked at the cells underneath a microscope.

Which of the following pictures should Jordanna's cheek cells most likely resemble?

- (1)
- (2)
- (3)
- (4)

778. Which part of a cell contains genetic material?

- (1) **nucleus**
- (2) cell membrane
- (3) vacuole
- (4) endoplasmic reticulum

799. The ribosome is an organelle that functions in

- (1) phagocytosis
- (2) pinocytosis
- (3) **protein synthesis**
- (4) cellular respiration